

# Street Design: Construction Details



**ITDP**

Institute for Transportation  
& Development Policy

# Footpath



# Footpath design: The zone system

Good footpaths have 3 clear zones:

1. **Pedestrian zone:** continuous space for walking
2. **Frontage zone:** buffer between street-side activities and the pedestrian zone
3. **Furniture zone:** space for landscaping, furniture, lights, bus stops, signs and private property access ramps

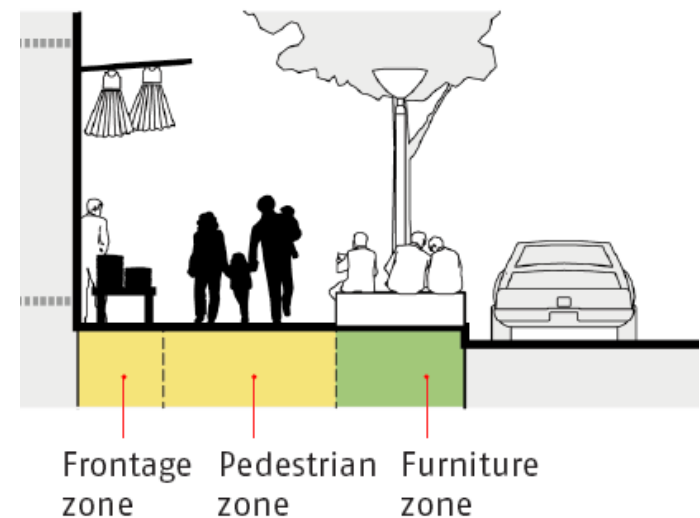
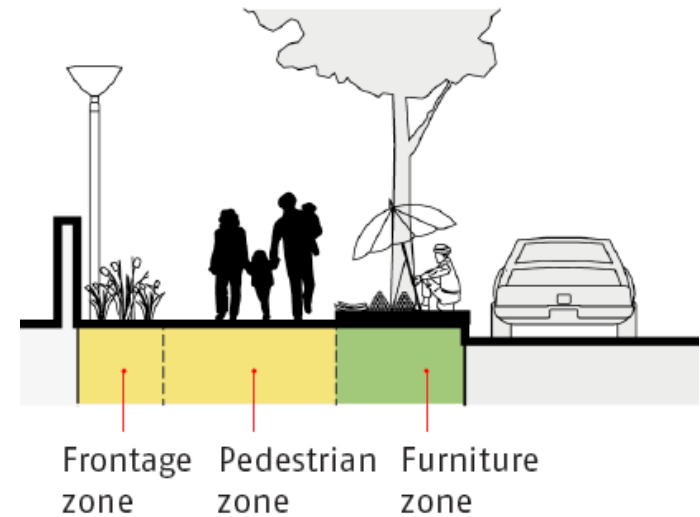



SAREES  
LADIES WEAR

GENTS WEAR  
CHILDRENS WEAR

Ohlibaby



SAREES  
LADIES WEAR

GENTS WEAR  
CHILDRENS WEAR

WELCOME  
to the  
POINTE BAZAAR

Furniture  
zone

Pedestrian zone

Frontage  
zone

# Pedestrian zone construction details

A blue horizontal bar spans the width of the slide. On the right side of this bar, there is a faint, light blue geometric pattern consisting of overlapping lines and shapes, resembling a stylized star or a complex architectural detail.

# Footpath details

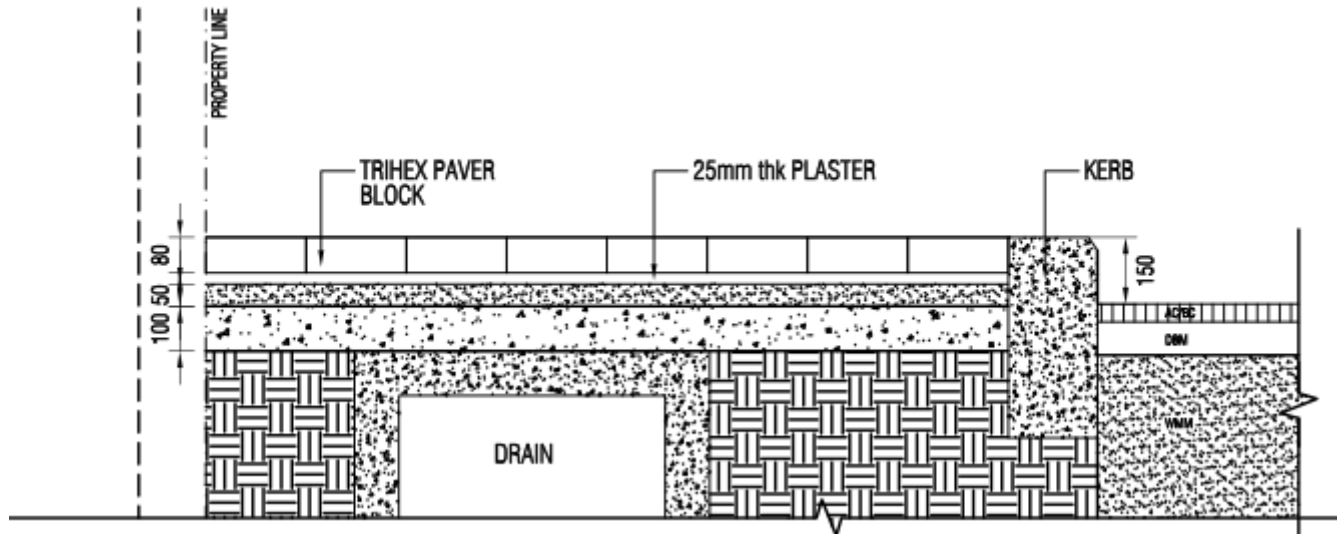

Paver blocks above storm water drains

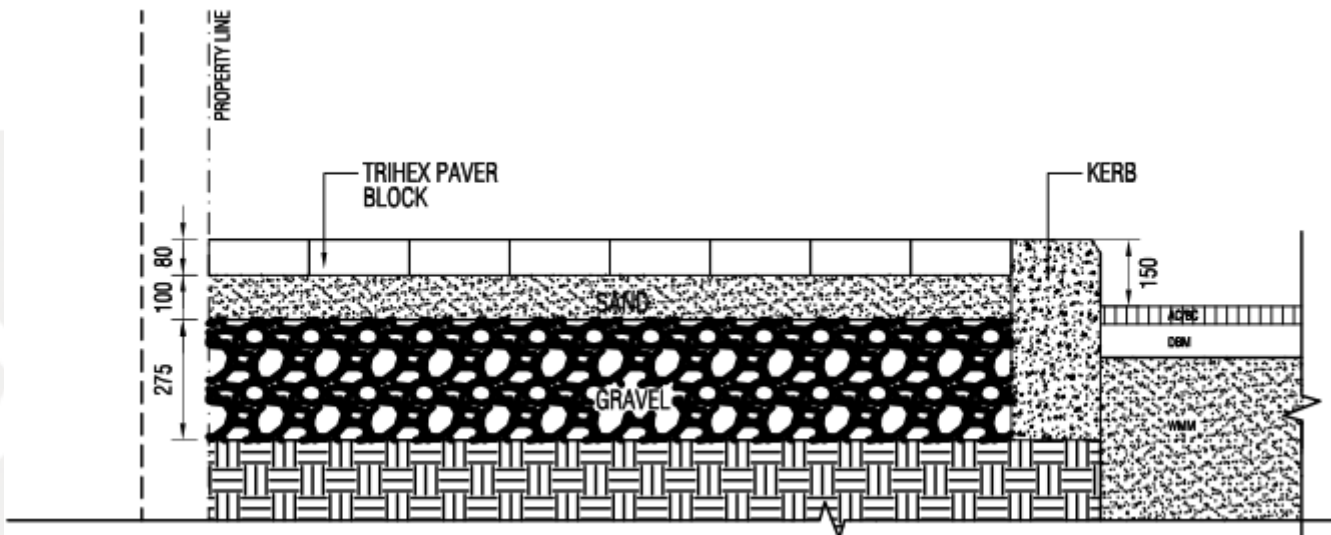

Paver blocks on sub base

# Concrete and asphalt

- Loyala college example



# Footpath surface details

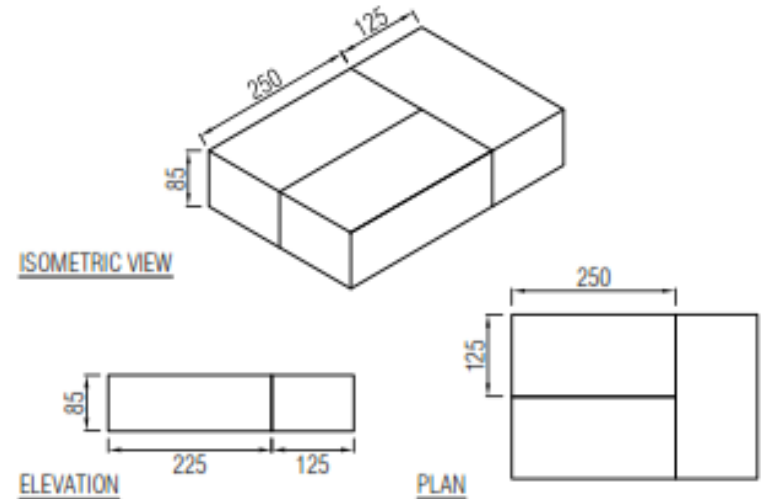
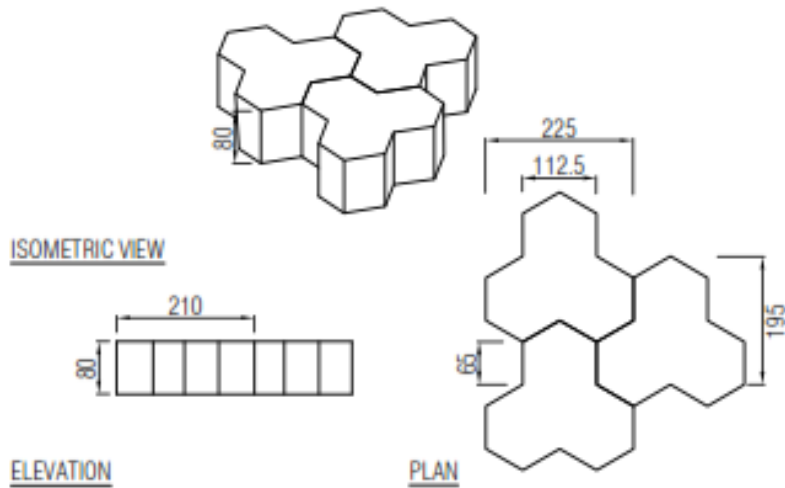

## TYPE A

Paver Block - Trihex

Size: 80mm thk

Material - M-20 cement concrete

Use: At pedestrian paths

## TYPE A

Paver Block

Size: 85 x 125 x 250

Material - M-20 cement concrete

Use: At utility edge and junctions



Evenly paved footpaths are convenient and comfortable for walking.



# Furniture zone construction details

A blue horizontal bar spans the width of the slide. On the right side of this bar, there is a faint, light blue geometric pattern consisting of overlapping lines forming a star-like or web-like structure.

# Kerb design

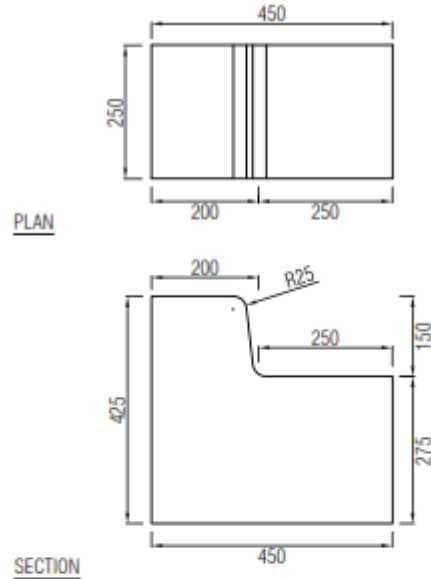

SECTION

ISOMETRIC VIEW

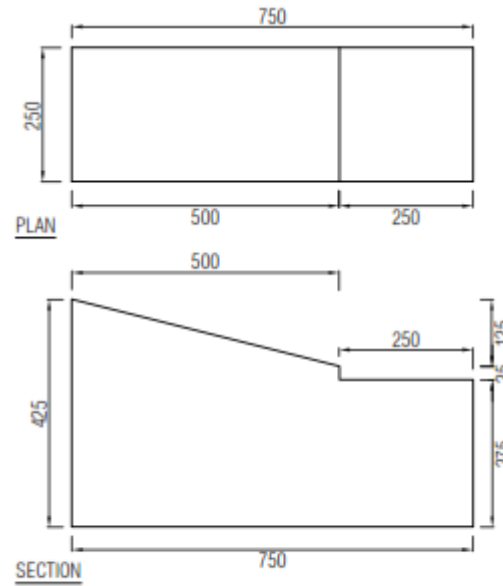

SECTION

ISOMETRIC VIEW

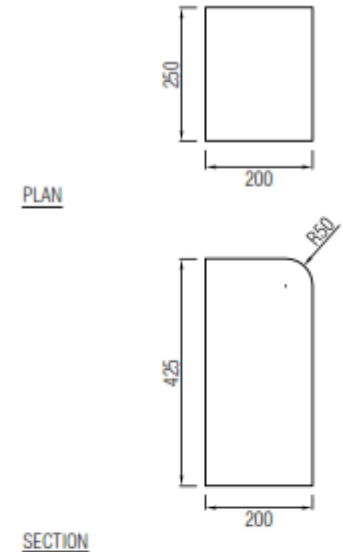

SECTION

ISOMETRIC VIEW

## TYPE A

Material: precast cement concrete

Use: At carriageway edge

## TYPE B

Material: precast cement concrete

Use: At property access ramp

## TYPE C

Material: precast cement concrete

Use: At tree line edge

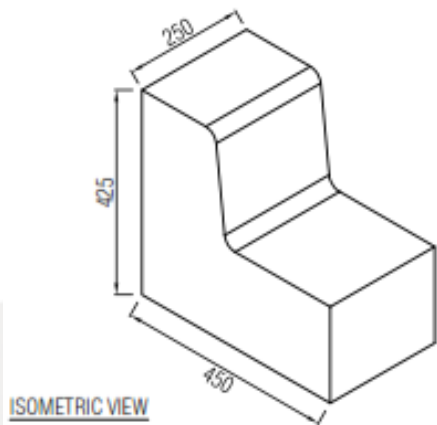
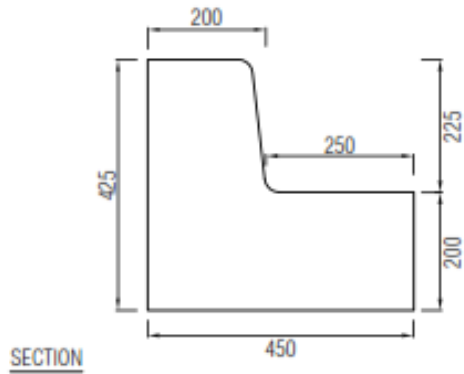
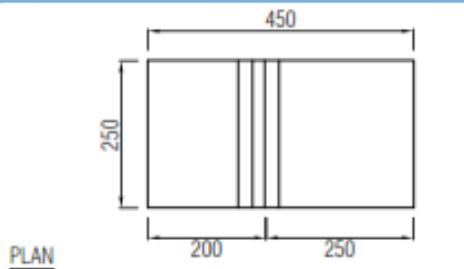

### **TYPE D**

Material: precast cement concrete

Use: At Median

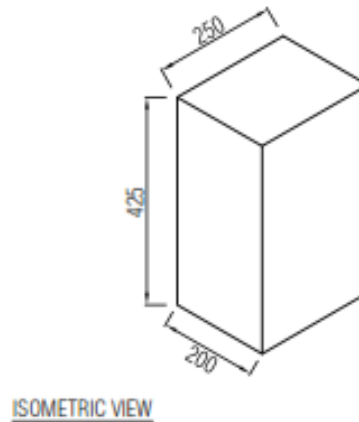
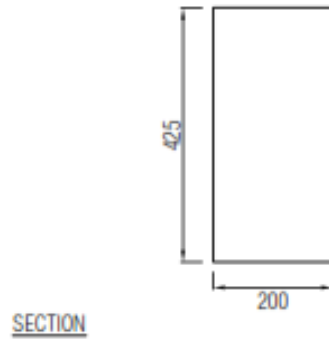
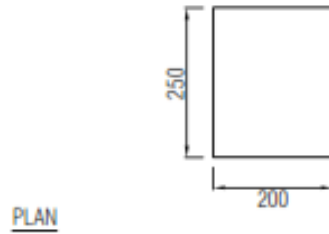

### **TYPE D**

Material: precast cement concrete

Use: As edging between sidewalk and cycle track

Well defined kerbs physically segregate footpaths and carriageways.



# Storm water drainage - through catchpit details

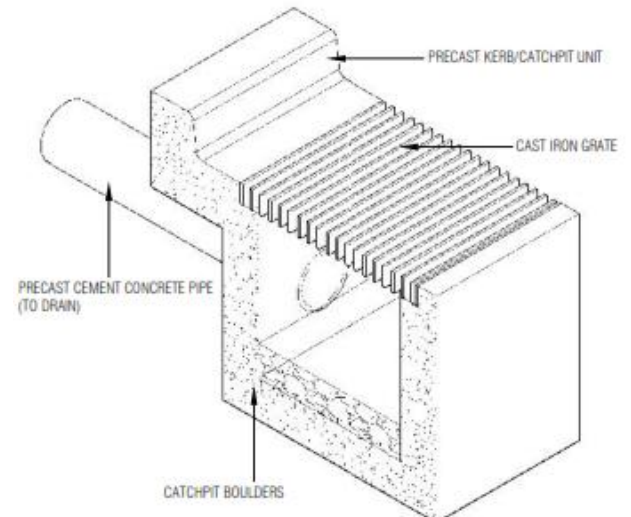
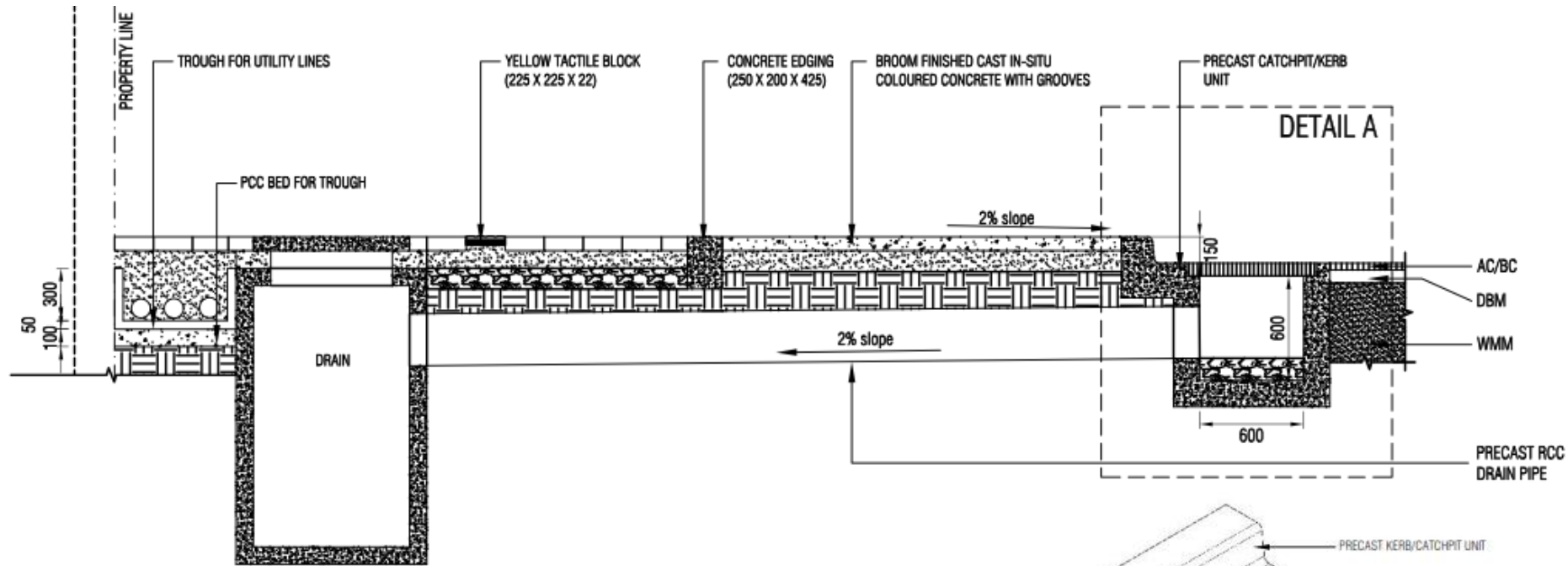

**ISOMETRIC CROSS-SECTION - DETAIL A**

# Storm water drainage - through access ramp details

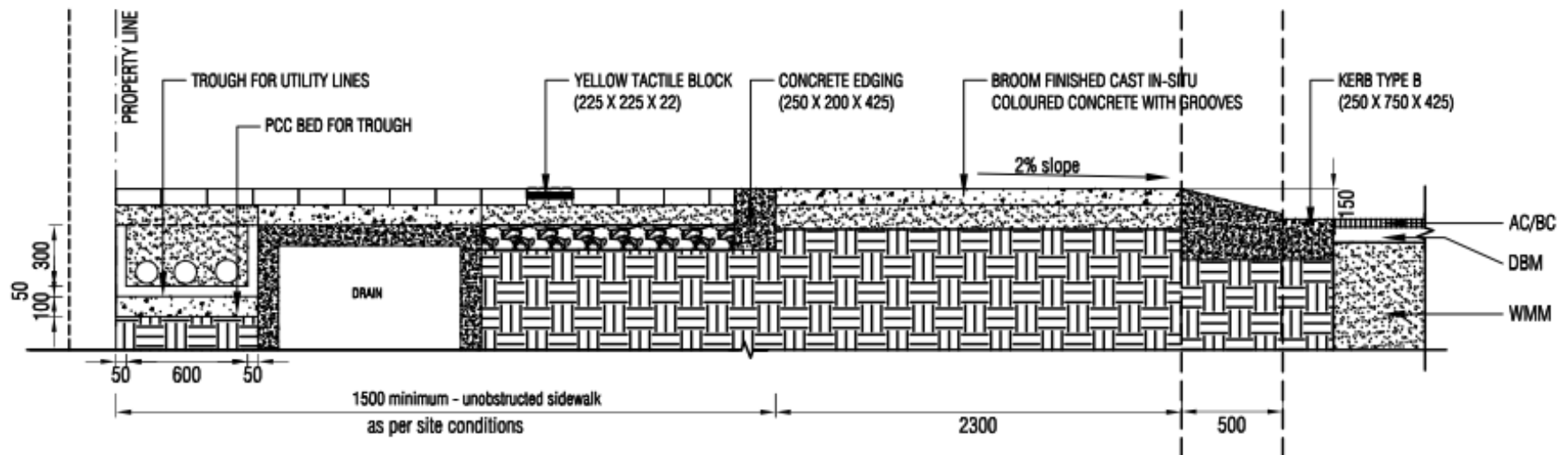

Drains should be in level with road surface and designed so that they do not hinder walking and/cycling.

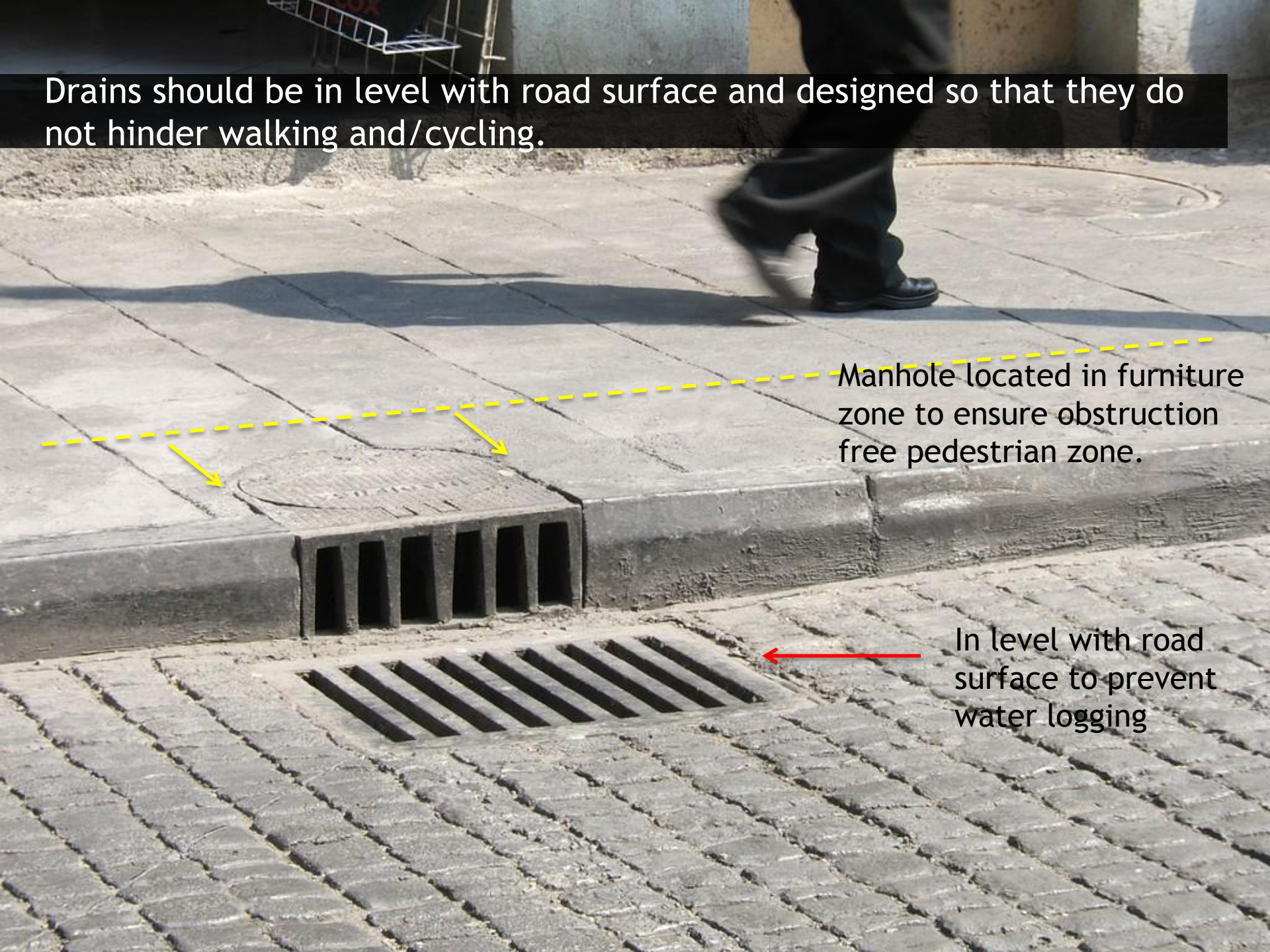

Manhole located in furniture zone to ensure obstruction free pedestrian zone.

In level with road surface to prevent water logging



# Tree pits design

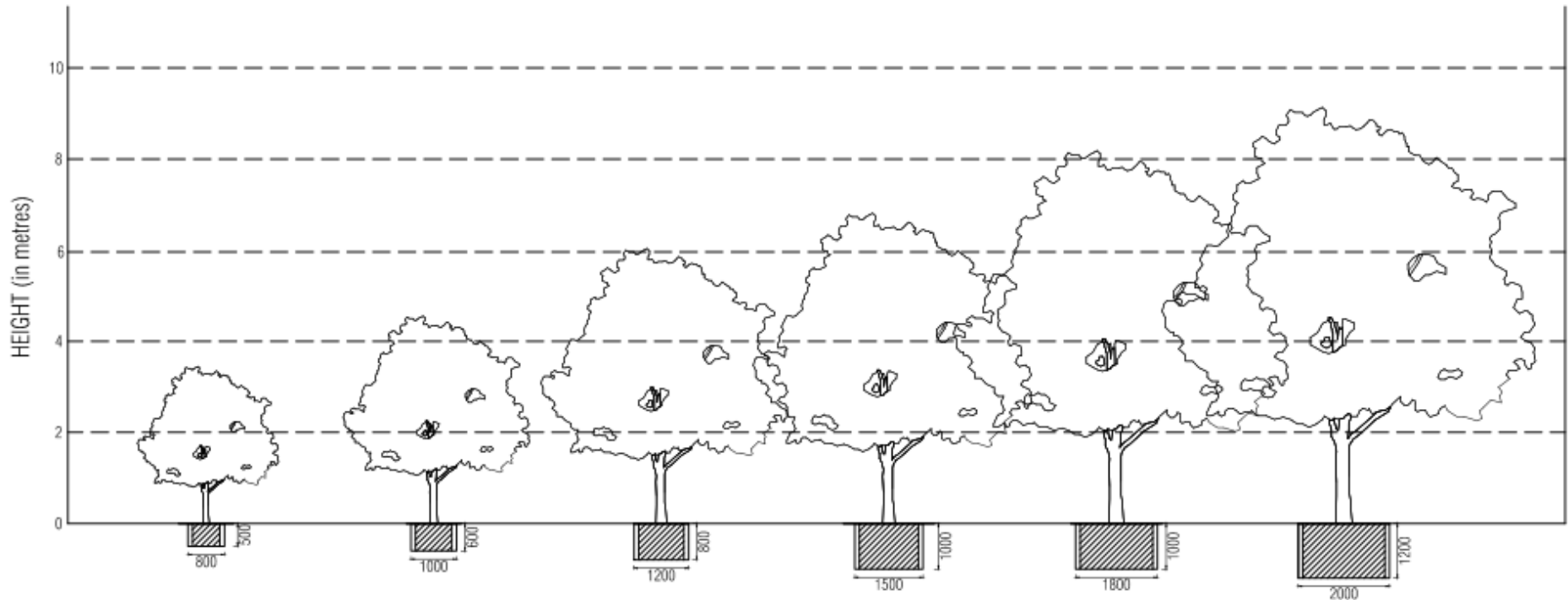

Tree grate size depends on height and canopy of the tree.  
Standardised tree grate size is 1200 mm x 1200 mm; 2000 mm x 2000 mm

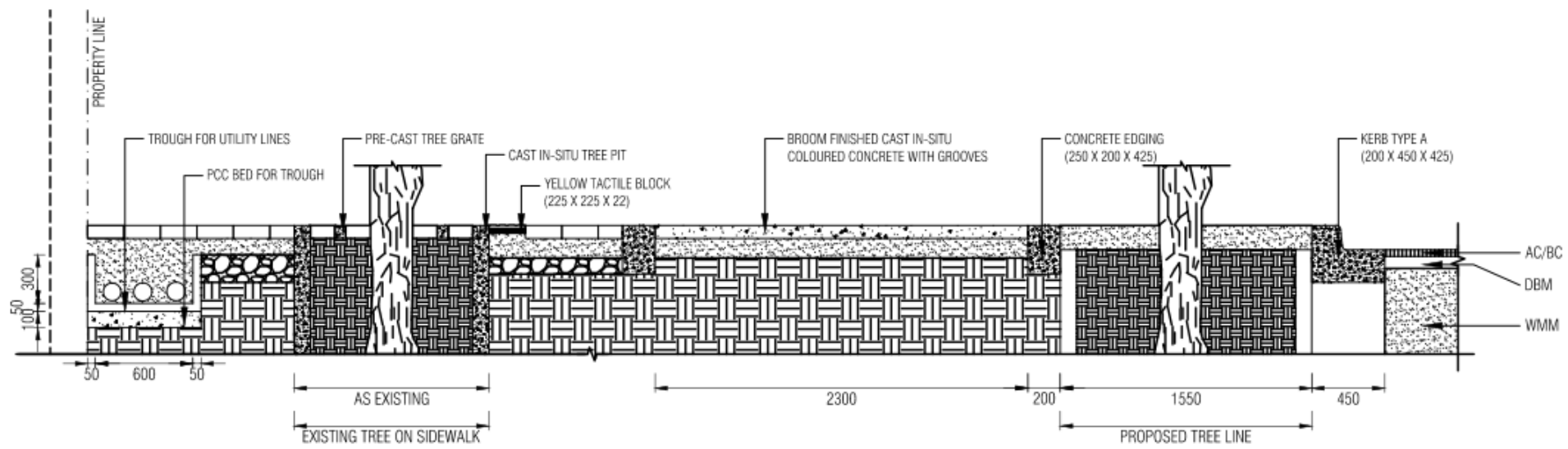

Tree line section



Tree pits should be placed in furniture zone at regular intervals to provide shading.



# Street furniture design

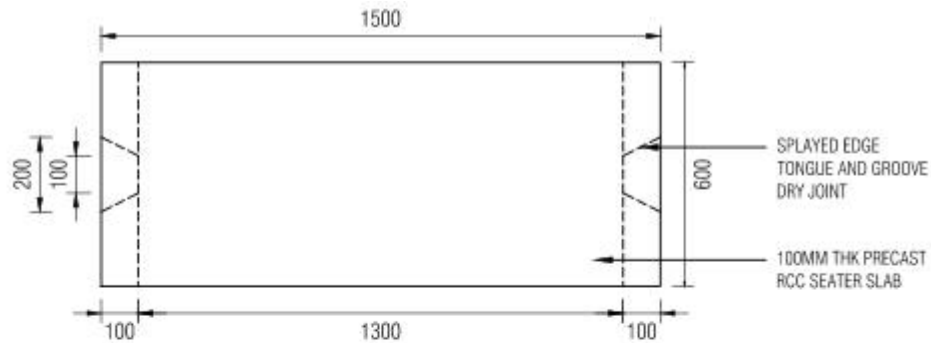

PLAN

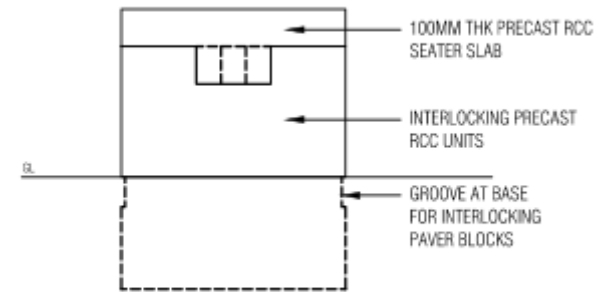

ELEVATION

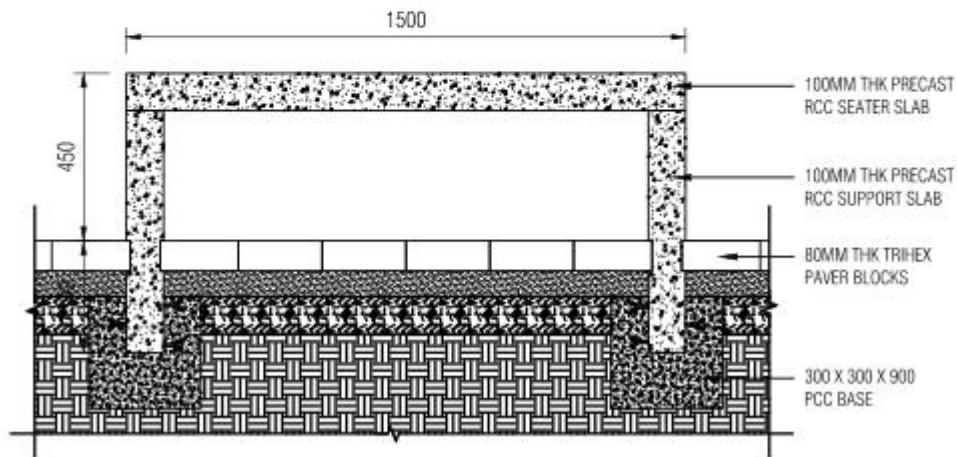

SECTION

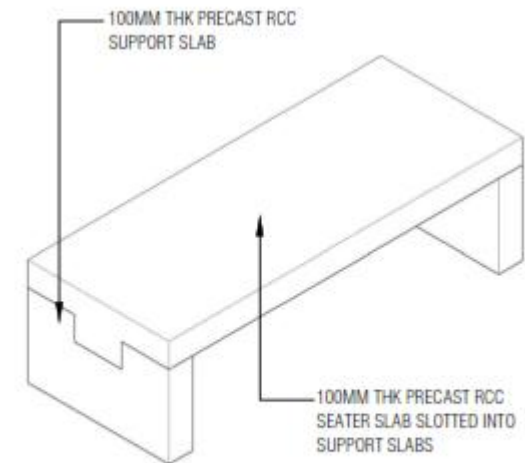

ISOMETRIC VIEW

Seaters should be located in furniture zone with trees for shading.



# Bollard design

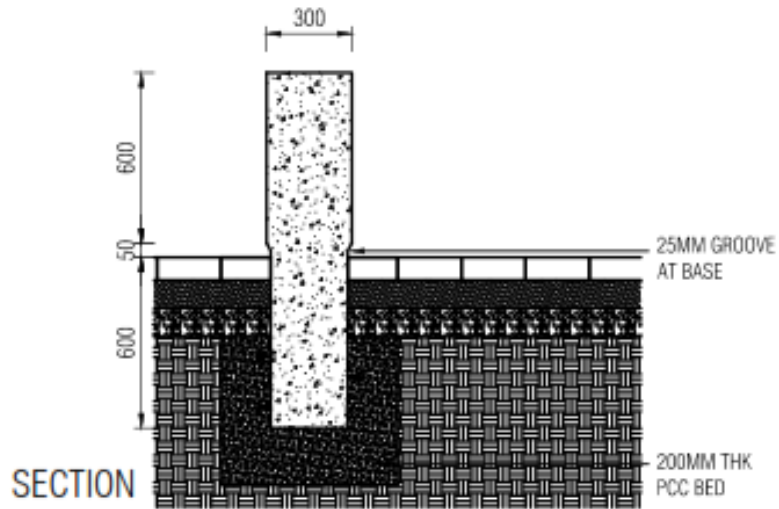

PLAN



BOLLARD DETAIL

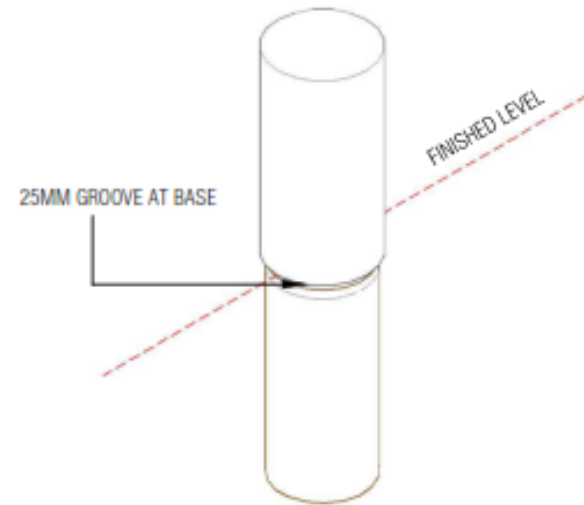

ISOMETRIC VIEW

Bollards at regular intervals refrain vehicles from driving/parking over footpaths



# Road markings





# Junction marking details

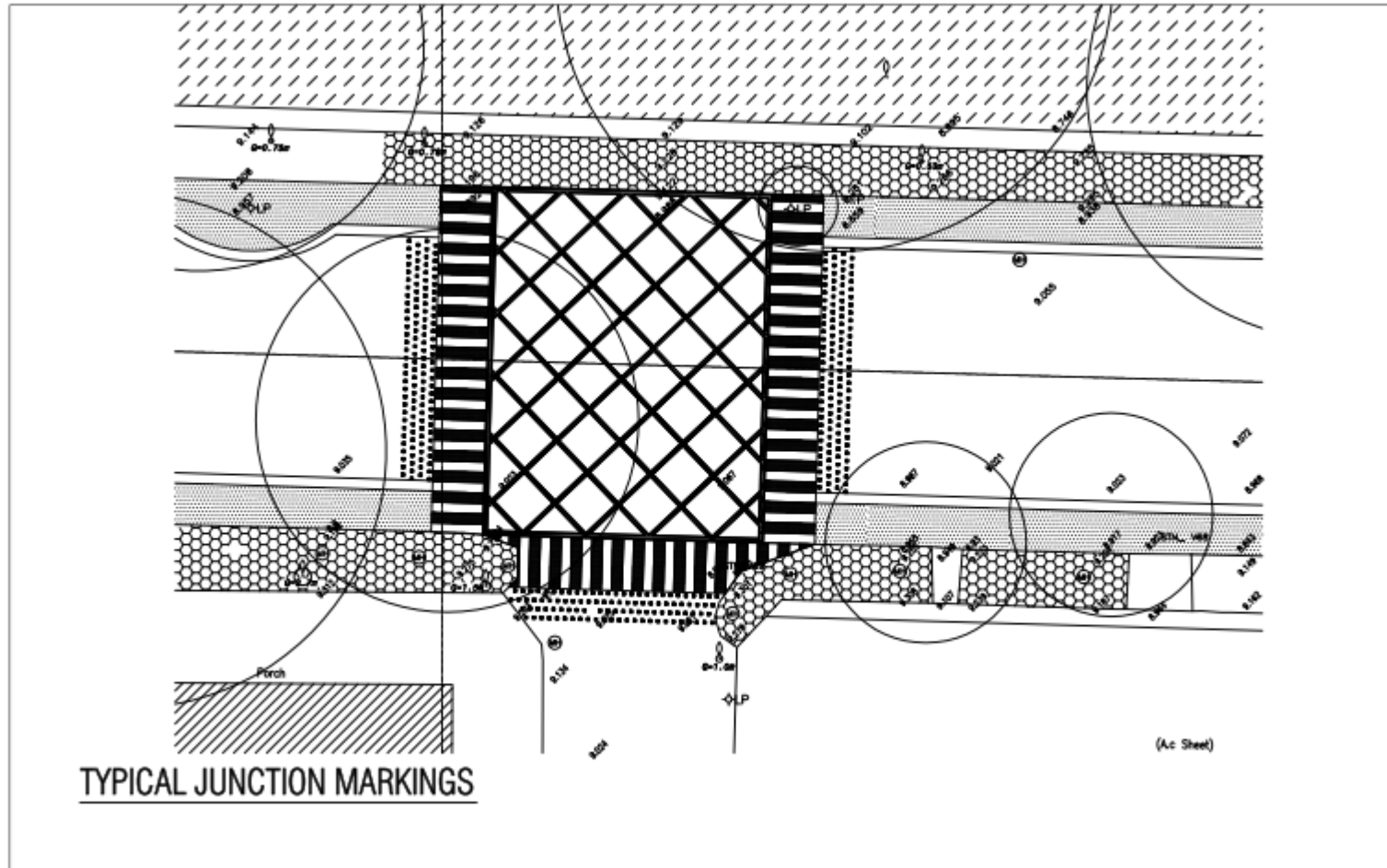

Road marking at a raised pedestrian crossing.

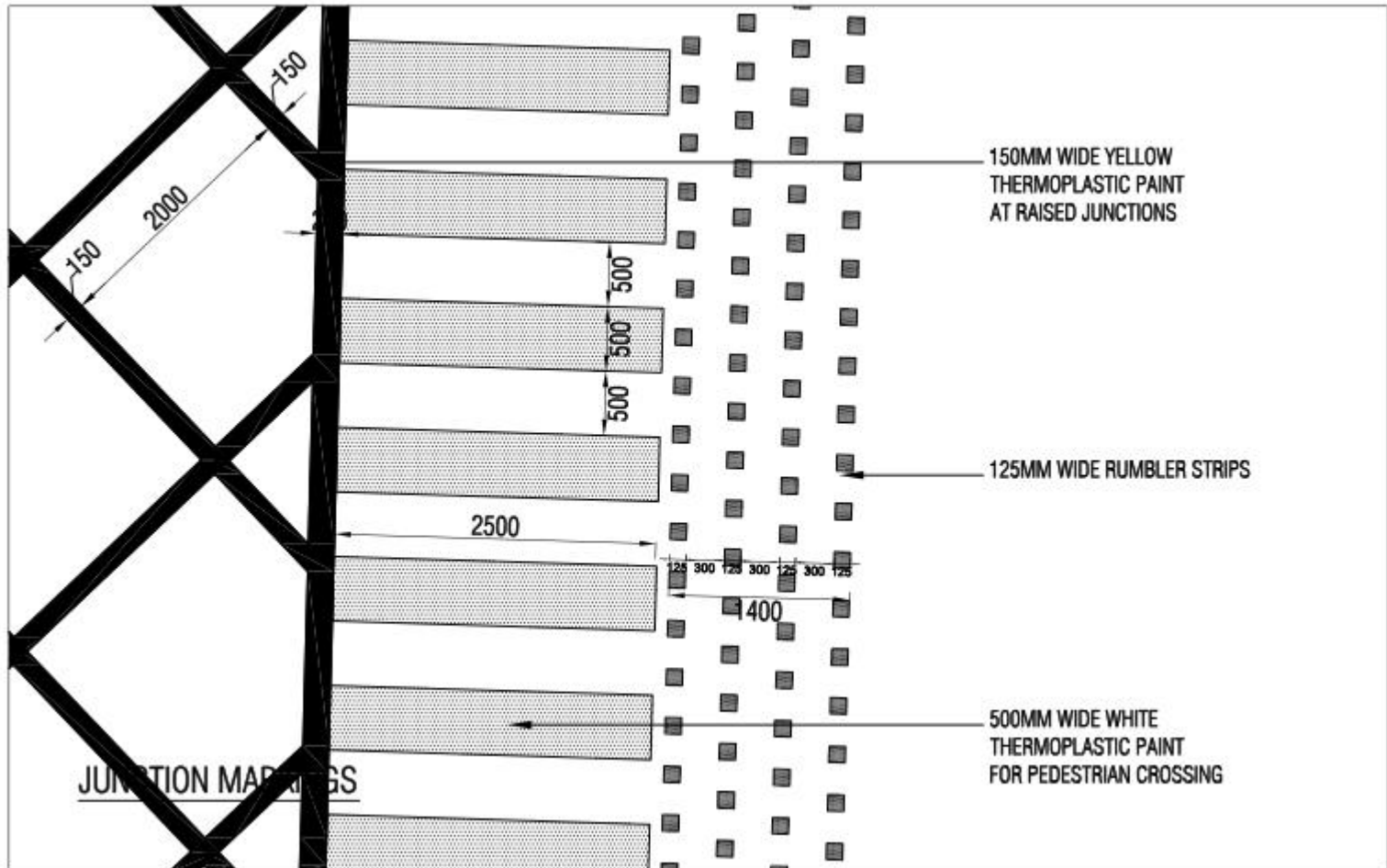

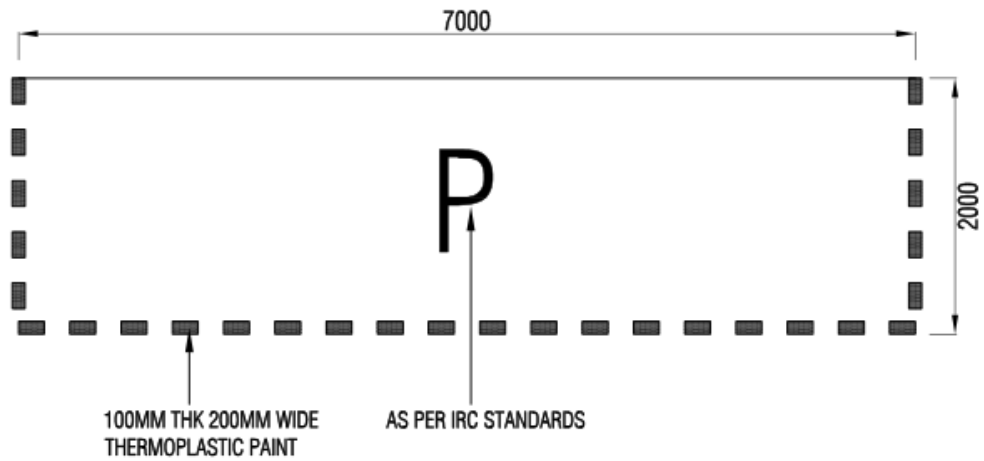

## PARKING MARKING

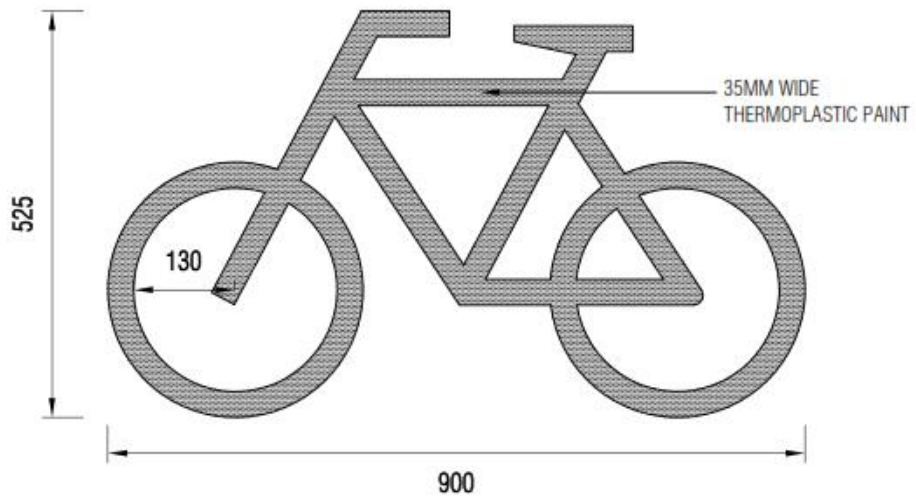

**BICYCLE TEMPLATE**  
 AT EVERY 10M INTERVAL AT BICYCLE TRACK

**Thank you**

[www.itdp.org](http://www.itdp.org)  
[twitter.com/itdpindia](https://twitter.com/itdpindia)